



# 100V N-Channel SGT Power MOSFET

## General Description

The SJD165N10 uses SGT technology to provide excellent  $R_{ds(on)}$ , low gate charge and fast switching characteristics. This device is suitable for use as a wide variety of applications.

## Features

- Low Gate Charge
- 100% UIS Tested, 100% DVDS Tested
- High Power and current handing capability
- Lead free product is acquired

## Application

- DC/DC Converter
- Motor Drivers

## Key Performance Parametes

Parameter	Value	Unit
$V_{DS}$	100	V
$R_{DS(ON\_TYP)}$	14.1	m $\Omega$
$I_D$	45	A
$Q_G$	11	nC



## Package Marking and Ordering Information

Device/Ordering Code	Marking	Package	Packing	Reel Size	Tape width	Quantity
SJD165N10	SJD165N10	TO-252	Tape	\	\	2500 Pcs

**Table 1. Absolute Maximum Ratings ( $T_C=25^\circ\text{C}$  unless otherwise noted)**

Symbol	Parameter	Limit	Unit
$V_{DS}$	Drain-Source Voltage ( $V_{GS}=0V$ )	100	V
$V_{GS}$	Gate-Source Voltage ( $V_{DS}=0V$ )	$\pm 20$	V
$I_D$	Drain Current-Continuous( $T_C=25^\circ\text{C}$ )	45	A
	Drain Current-Continuous( $T_C=100^\circ\text{C}$ )	29	A
$I_{DM}$ (pluse)	Drain Current-Continuous@ Current-Pulsed (Note 1)	180	A
$P_D$	Maximum Power Dissipation( $T_C=25^\circ\text{C}$ )	69	W
	Maximum Power Dissipation( $T_C=100^\circ\text{C}$ )	28	W
$E_{AS}$	Avalanche energy (Note 2)	121	mJ
$T_J, T_{STG}$	Operating Junction and Storage Temperature Range	-55 To 150	$^\circ\text{C}$

**Table 2. Thermal Characteristic**

Symbol	Parameter	Typ	Max	Unit
$R_{\theta JC}$	Thermal Resistance, Junction-to-Case		1.8	$^\circ\text{C/W}$



# 100V N-Channel SGT Power MOSFET

**Table 3. Electrical Characteristics ( $T_J=25^{\circ}\text{C}$  unless otherwise noted)**

Symbol	Parameter	Conditions	Min	Typ	Max	Unit
<b>On/Off States</b>						
$BV_{DSS}$	Drain-Source Breakdown Voltage	$V_{GS}=0V, I_D=250\mu A$	100			V
$I_{DSS}$	Zero Gate Voltage Drain Current	$V_{DS}=100V, V_{GS}=0V, T_J=25^{\circ}\text{C}$			1	$\mu A$
		$V_{DS}=100V, V_{GS}=0V, T_J=125^{\circ}\text{C}$			100	$\mu A$
$I_{GSS}$	Gate-Body Leakage Current	$V_{GS}=\pm 20V, V_{DS}=0V$			$\pm 100$	nA
$V_{GS(th)}$	Gate Threshold Voltage	$V_{DS}=V_{GS}, I_D=250\mu A$	2		4	V
$g_{FS}$	Forward Transconductance	$V_{DS}=10V, I_D=20A$		30		S
$R_{DS(ON)}$	Drain-Source On-State Resistance	$V_{GS}=10V, I_D=20A, T_J=25^{\circ}\text{C}$		14.1	18.3	m $\Omega$
<b>Dynamic Characteristics</b>						
$C_{iss}$	Input Capacitance	$V_{DS}=50V, V_{GS}=0V, f=1.0\text{MHz}$		760		pF
$C_{oss}$	Output Capacitance			192		pF
$C_{rss}$	Reverse Transfer Capacitance			8.7		pF
$R_g$	Gate resistance	$V_{GS}=0V, V_{DS}=0V, f=1.0\text{MHz}$		0.9		$\Omega$
<b>Switching Parameters</b>						
$t_{d(on)}$	Turn-on Delay Time	$V_{GS}=10V, V_{DS}=50V, R_L=2.5\Omega, R_{GEN}=6\Omega$		9		nS
$t_r$	Turn-on Rise Time			16		nS
$t_{d(off)}$	Turn-Off Delay Time			15		nS
$t_f$	Turn-Off Fall Time			8		nS
$Q_g$	Total Gate Charge	$V_{GS}=10V, V_{DS}=50V, I_D=20A$		11		nC
$Q_{gs}$	Gate-Source Charge			4		nC
$Q_{gd}$	Gate-Drain Charge			3.5		nC
<b>Source-Drain Diode Characteristics</b>						
$I_{SD}$	Source-Drain Current (Body Diode)				45	A
$V_{SD}$	Forward on Voltage (Note 3)	$V_{GS}=0V, I_S=20A$			1.2	V
$t_{rr}$	Reverse Recovery Time	$I_F=20A, dI/dt=500A/\mu s$		29		ns
$Q_{rr}$	Reverse Recovery Charge	$I_F=20A, dI/dt=500A/\mu s$		70		nC

Notes 1.Repetitive Rating: Pulse width limited by maximum junction temperature.

Notes 2.EAS condition:  $T_J=25^{\circ}\text{C}, V_{DD}=50V, V_G=10V, R_g=25\Omega, L=0.5\text{mH}$ .

Notes 3.Repetitive Rating: Pulse width limited by maximum junction temperature.



Typical Electrical And Thermal Characteristics (Curves)

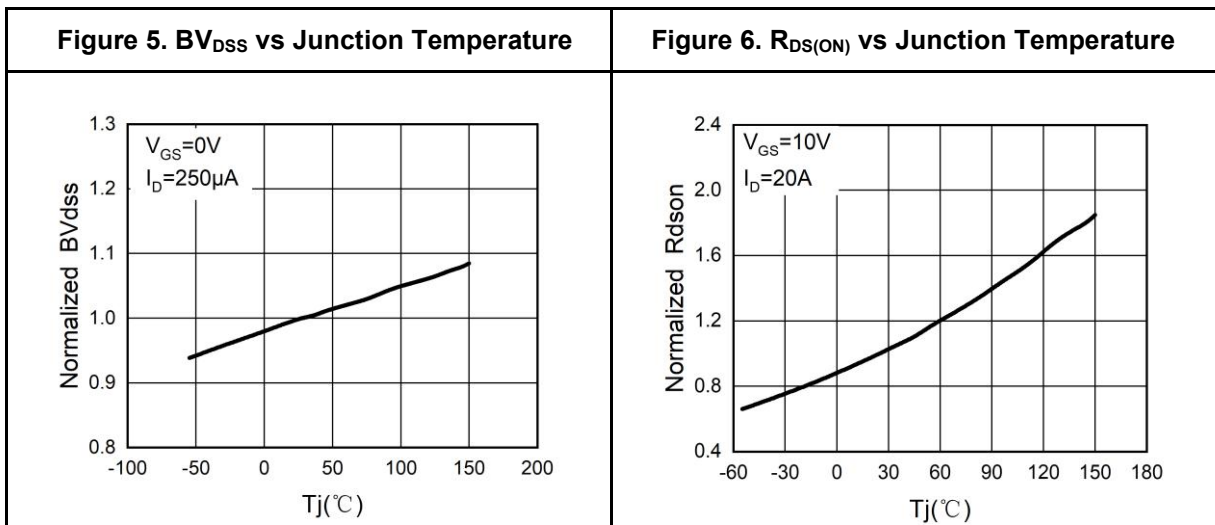
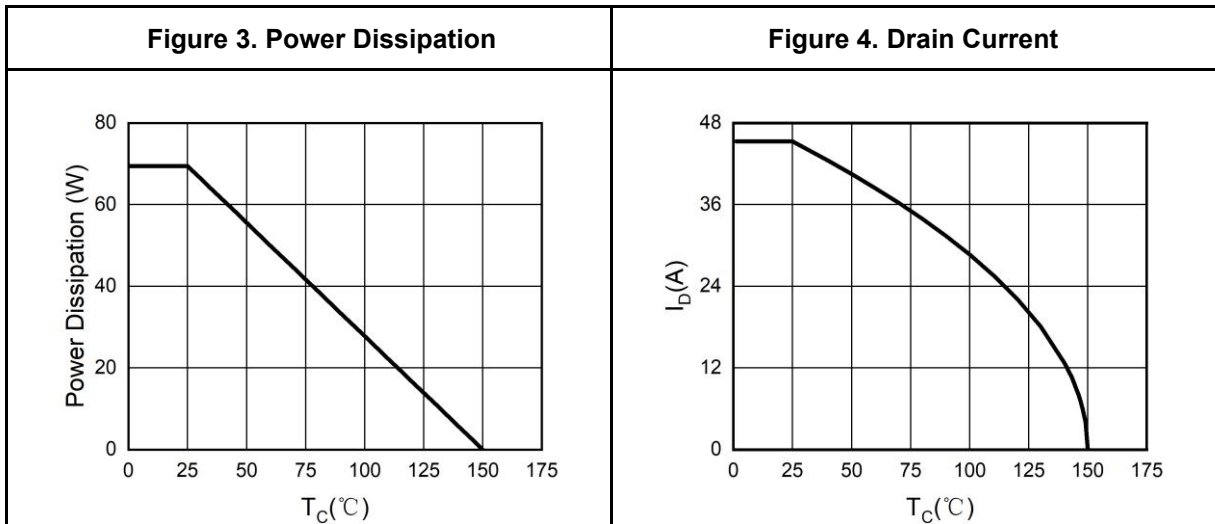
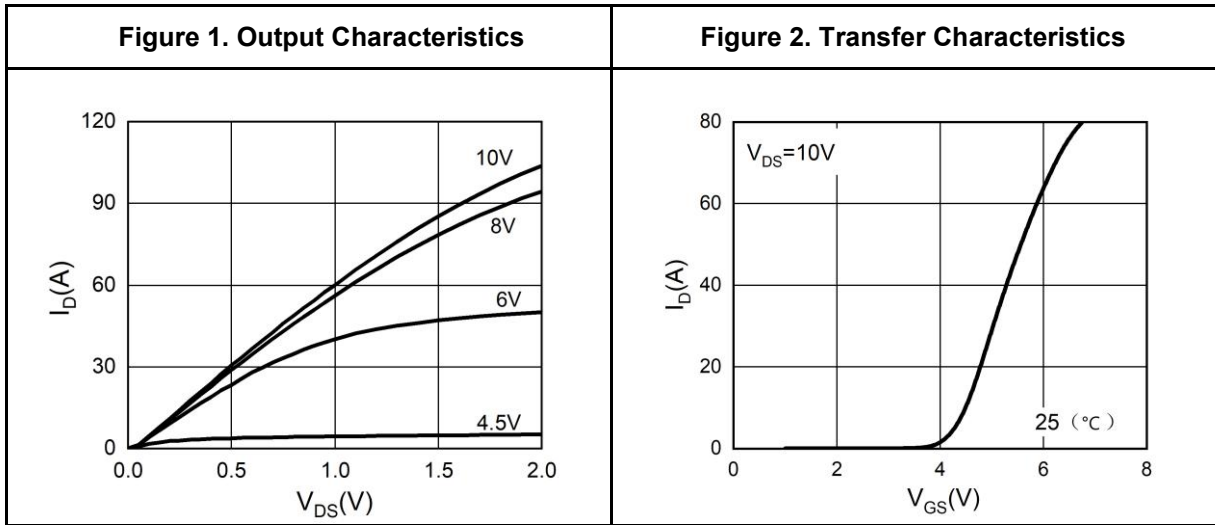



Typical Electrical And Thermal Characteristics (Curves)

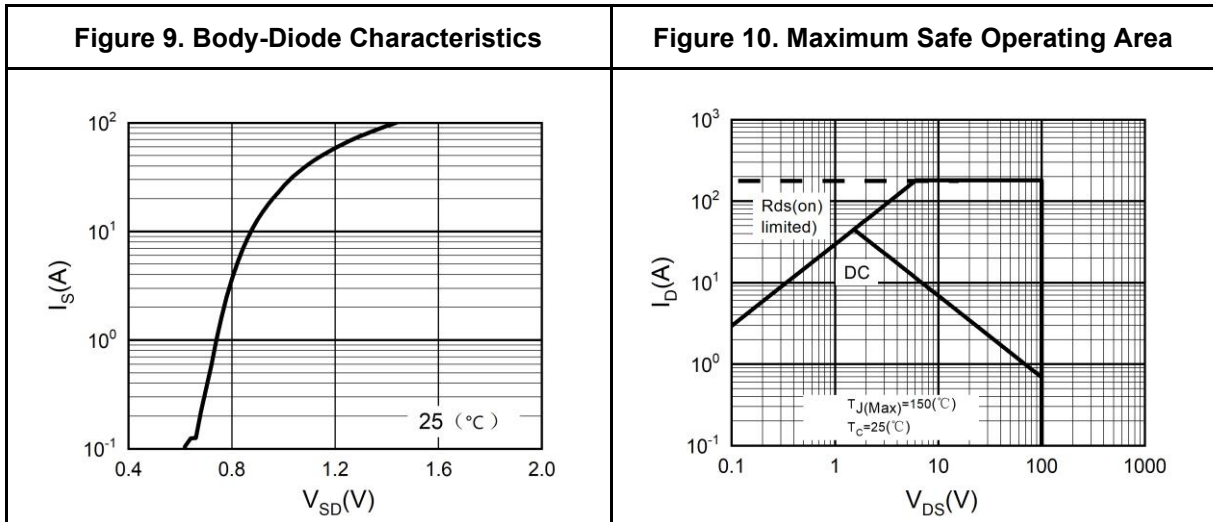
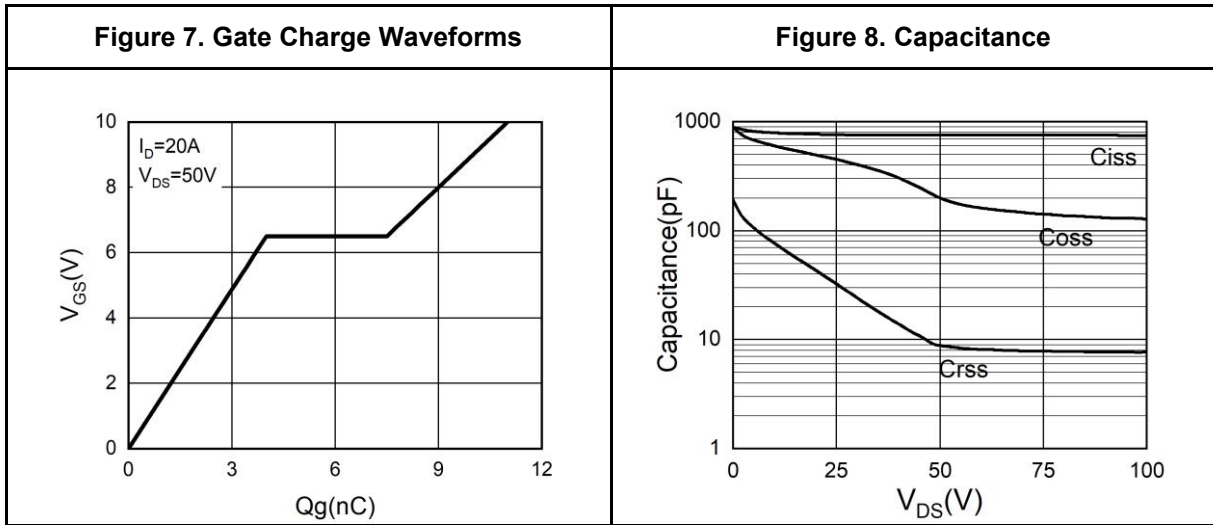



TO-252 Package Information

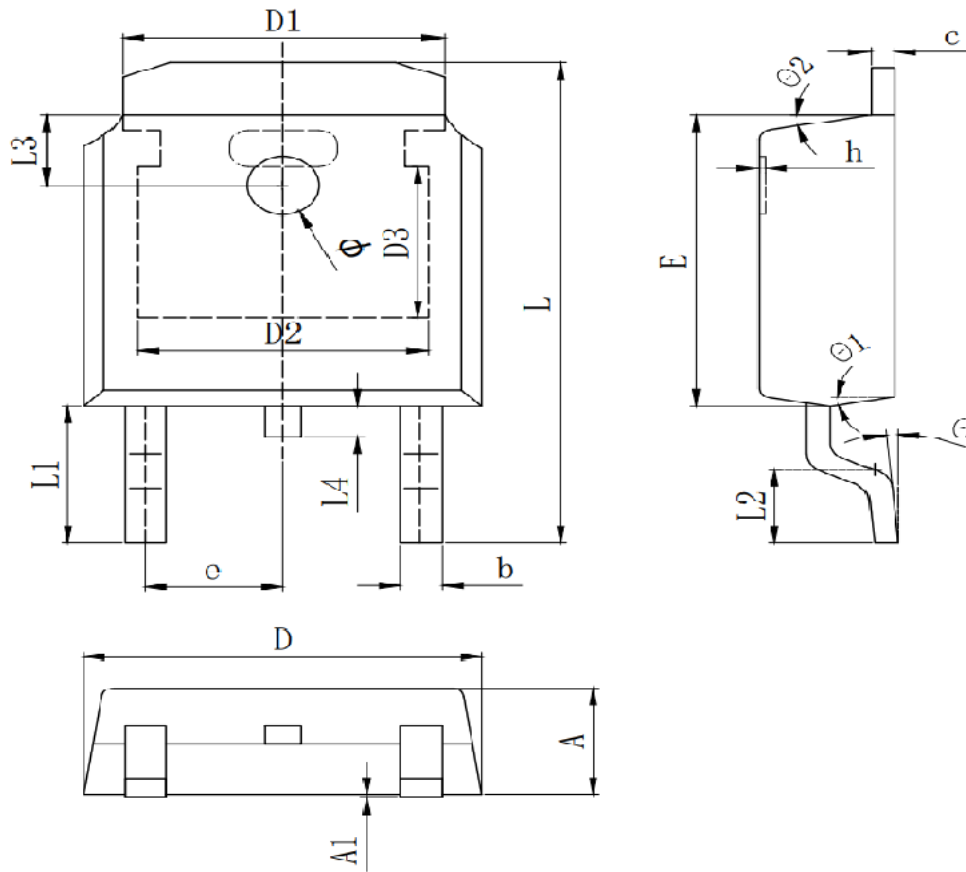

Symbol	Dimensions In Millimeters		
	Min.	Typ.	Max.
A	2.200	2.300	2.400
A1	0.000		0.127
b	0.640	0.690	0.740
c(电镀后)	0.460	0.520	0.580
D	6.500	6.600	6.700
D1		5.334 REF	
D2		4.826 REF	
D3		3.166 REF	
E	6.000	6.100	6.200
e		2.286 TYP	
h	0.000	0.100	0.200
L	9.900	10.100	10.300
L1		2.888 REF	
L2	1.400	1.550	1.700
L3		1.600 REF	
L4	0.600	0.800	1.000
Φ	1.100	1.200	1.300
θ	0°		8°
θ1		9° TYP	
θ2		9° TYP	



## Attention

This product described in this document can not be used in life support devices or systems, aircraft's control systems, and other applications whose failure can be reasonably expected to result in serious physical and/or material damage, apart from that when an application agreement is signed between customer and Wuxi Shangjia Semiconductor.

The performances and characteristics of this product in the independent testing state are displayed in this document. Wuxi Shangjia Semiconductor can't guarantee of the performances and characteristics of this described product that mounted in the customer's products or equipments as same as that in the independent testing state. So the customer should evaluate and test devices mounted in the customer's products or equipments.

Wuxi Shangjia Semiconductor reserves the right to improve the designs, functions and reliability of this product and modify any and all information described in this document without notice customer, apart from that when a notice agreement is signed between customer and Wuxi Shangjia Semiconductor.

The information given in this document shall in no event be regarded as a guarantee of conditions or characteristics. With respect to any examples or hints given herein, any typical values stated herein and/or any information regarding the application of the device, Wuxi Shangjia Semiconductor hereby disclaims any and all warranties and liabilities of any kind, including without limitation, warranties of non-infringement of intellectual property rights of any third party.