



## 40V P-Channel Trench Power MOSFET

### General Description

The SJA40P300 uses advanced trench technology to provide excellent  $R_{DS(ON)}$ , low gate charge and operation with gate voltages as low as -4.5V. This device is suitable for use as a wide variety of applications.

### Features

- Low Gate Charge
- 100% UIS Tested, 100% DVDS Tested
- High Power and current handling capability
- Lead free product is acquired

### Application

- PWM Applications
- Load Switch
- Power Management

### Key Performance Parameters

Parameter	Value	Unit
$V_{DS}$	-40	V
$R_{DS(ON\_TYP)}$	35.6	m $\Omega$
$I_D$	-5.9	A
$Q_G$	19.6	nC



### Package Marking and Ordering Information

Device/Ordering Code	Marking	Package	Packing	Reel Size	Tape width	Quantity
SJA40P300	SJA40P300	SOT-23-3L	Tape	\	\	3000 Pcs

**Table 1. Absolute Maximum Ratings ( $T_A=25^\circ\text{C}$  unless otherwise noted)**

Symbol	Parameter	Limit	Unit
$V_{DS}$	Drain-Source Voltage ( $V_{GS}=0V$ )	-40	V
$V_{GS}$	Gate-Source Voltage ( $V_{DS}=0V$ )	$\pm 20$	V
$I_D$	Drain Current-Continuous( $T_A=25^\circ\text{C}$ )	-5.9	A
	Drain Current-Continuous( $T_A=100^\circ\text{C}$ )	-4.8	A
$I_{DM}$ (pluse)	Drain Current-Continuous@ Current-Pulsed (Note 1)	-23.6	A
$P_D$	Maximum Power Dissipation( $T_A=25^\circ\text{C}$ )	2.7	W
	Maximum Power Dissipation( $T_A=100^\circ\text{C}$ )	1.1	W
$E_{AS}$	Avalanche energy (Note 2)	64	mJ
$T_J, T_{STG}$	Operating Junction and Storage Temperature Range	-55 To 150	$^\circ\text{C}$

**Table 2. Thermal Characteristic**

Symbol	Parameter	Typ	Max	Unit
$R_{\theta JA}$	Thermal Resistance, Junction-to-Ambient		46	$^\circ\text{C/W}$



## 40V P-Channel Trench Power MOSFET

**Table 3. Electrical Characteristics ( $T_J=25^\circ\text{C}$  unless otherwise noted)**

Symbol	Parameter	Conditions	Min	Typ	Max	Unit
<b>On/Off States</b>						
$BV_{DSS}$	Drain-Source Breakdown Voltage	$V_{GS}=0V, I_D=-250\mu A$	-40			V
$I_{DSS}$	Zero Gate Voltage Drain Current	$V_{DS}=-40V, V_{GS}=0V, T_J=25^\circ\text{C}$			-1	$\mu A$
		$V_{DS}=-40V, V_{GS}=0V, T_J=125^\circ\text{C}$			-100	$\mu A$
$I_{GSS}$	Gate-Body Leakage Current	$V_{GS}=\pm 20V, V_{DS}=0V$			$\pm 100$	nA
$V_{GS(th)}$	Gate Threshold Voltage	$V_{DS}=V_{GS}, I_D=-250\mu A$	-1		-2.5	V
$g_{FS}$	Forward Transconductance	$V_{DS}=-5V, I_D=-10A$		14		S
$R_{DS(ON)}$	Drain-Source On-State Resistance	$V_{GS}=-10V, I_D=-10A, T_J=25^\circ\text{C}$		35.6	44.5	m $\Omega$
$R_{DS(ON)}$	Drain-Source On-State Resistance	$V_{GS}=-4.5V, I_D=-8A, T_J=25^\circ\text{C}$		46.3	61.6	m $\Omega$
<b>Dynamic Characteristics</b>						
$C_{iss}$	Input Capacitance	$V_{DS}=-20V, V_{GS}=0V, f=1.0\text{MHz}$		1020		pF
$C_{oss}$	Output Capacitance			64		pF
$C_{rss}$	Reverse Transfer Capacitance			48		pF
$R_g$	Gate resistance	$V_{GS}=0V, V_{DS}=0V, f=1.0\text{MHz}$		4.7		$\Omega$
<b>Switching Parameters</b>						
$t_{d(on)}$	Turn-on Delay Time	$V_{GS}=-10V, V_{DS}=-20V, R_L=2\Omega, R_{GEN}=3\Omega$		13		nS
$t_r$	Turn-on Rise Time			16		nS
$t_{d(off)}$	Turn-Off Delay Time			180		nS
$t_f$	Turn-Off Fall Time			86		nS
$Q_g$	Total Gate Charge	$V_{GS}=-10V, V_{DS}=-20V, I_D=-10A$		19.3		nC
$Q_{gs}$	Gate-Source Charge			2.5		nC
$Q_{gd}$	Gate-Drain Charge			5.5		nC
<b>Source-Drain Diode Characteristics</b>						
$I_{SD}$	Source-Drain Current (Body Diode)				-5.9	A
$V_{SD}$	Forward on Voltage (Note 3)	$V_{GS}=0V, I_S=-10A$			-1.2	V
$t_{rr}$	Reverse Recovery Time	$I_F=-10A, di/dt=100A/\mu s$		34		ns
$Q_{rr}$	Reverse Recovery Charge	$I_F=-10A, di/dt=100A/\mu s$		35		nC

Notes 1.Repetitive Rating: Pulse width limited by maximum junction temperature.

Notes 2.EAS condition:  $T_J=25^\circ\text{C}, V_{DD}=40V, V_G=-10V, R_g=25\Omega, L=0.5\text{mH}$ .

Notes 3.Repetitive Rating: Pulse width limited by maximum junction temperature.



# 40V P-Channel Trench Power MOSFET

## Typical Electrical And Thermal Characteristics (Curves)

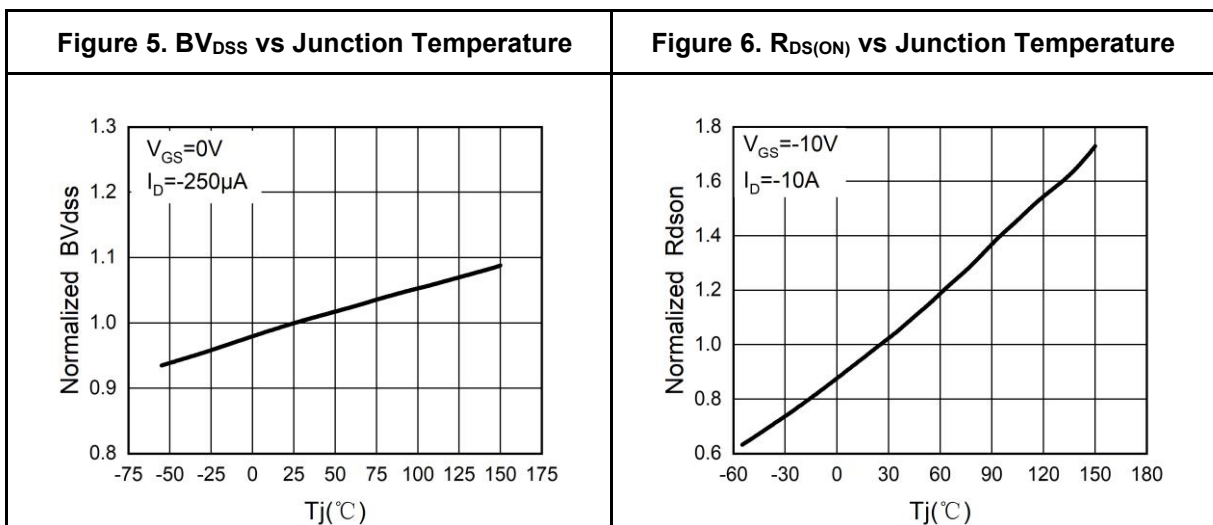
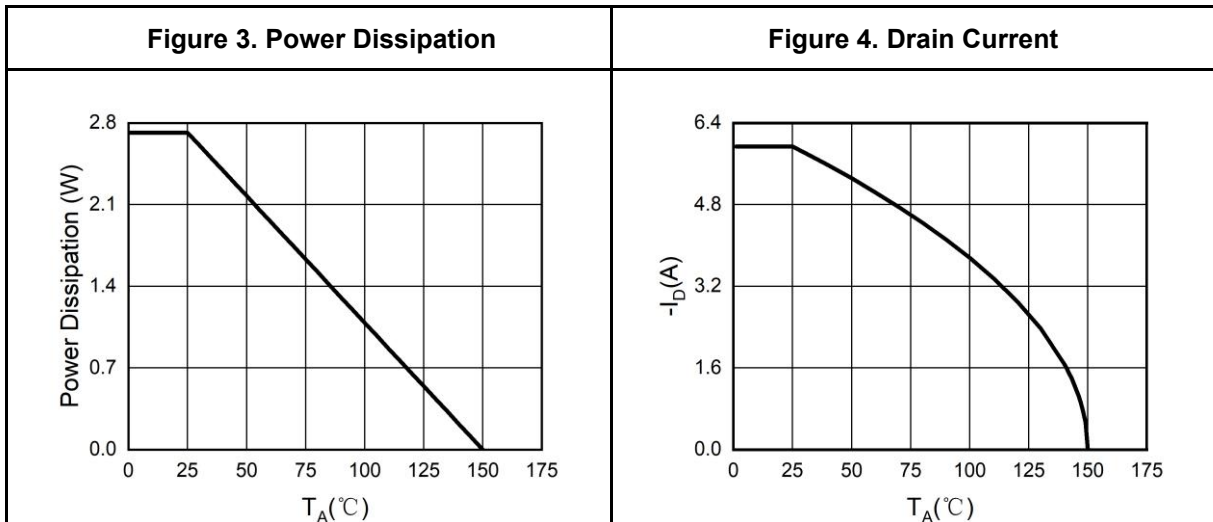
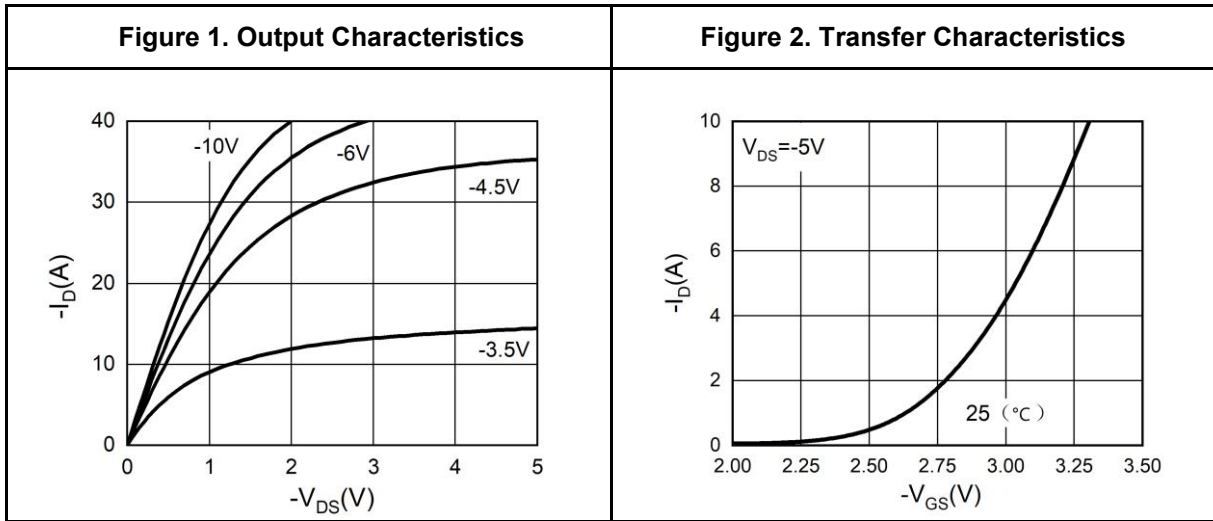



# 40V P-Channel Trench Power MOSFET

## Typical Electrical And Thermal Characteristics (Curves)

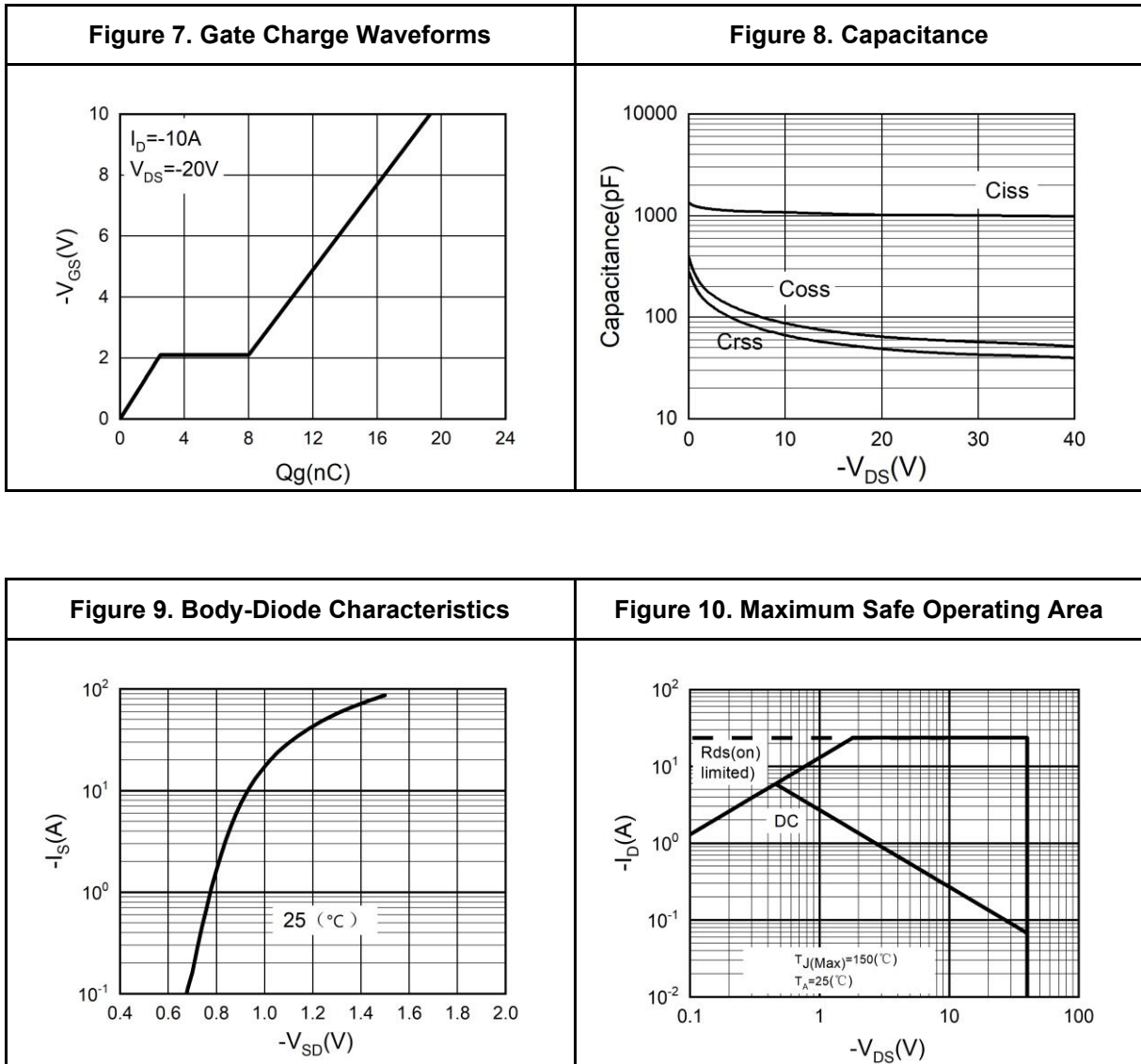



# 40V P-Channel Trench Power MOSFET

## SOT-23-3L Package Information

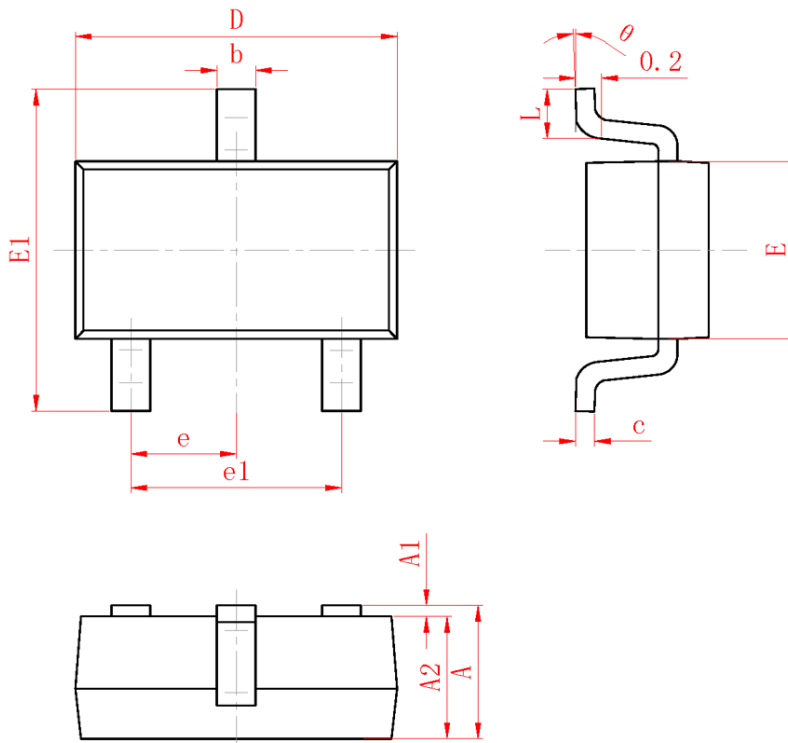

SYMBOL	MILLIMETER	
	MIN	MAX
A	1.050	1.250
A1	0.000	0.100
A2	1.050	1.150
b	0.250	0.450
c	0.100	0.200
D	2.820	3.020
E	1.500	1.700
E1	2.650	2.950
e	0.950 (BSC)	
e1	1.800	2.000
L	0.300	0.500
$\theta$	0°	8°

Symbol	Dimensions In Millimeters	
	Min.	Max.
A	1.050	1.250
A1	0.000	0.100
A2	1.050	1.150
b	0.250	0.450
c	0.100	0.200
D	2.820	3.020
E	1.500	1.700
E1	2.650	2.950
e	0.950(BSC)	
e1	1.800	2.000
L	0.300	0.500
$\theta$	0°	8°



## 40V P-Channel Trench Power MOSFET

---

### Attention

This product described in this document can not be used in life support devices or systems, aircraft's control systems, and other applications whose failure can be reasonably expected to result in serious physical and/or material damage, apart from that when an application agreement is signed between customer and Linde Semiconductor.

The performances and characteristics of this product in the independent testing state are displayed in this document. Linde Semiconductor can't guarantee of the performances and characteristics of this described product that mounted in the customer's products or equipments as same as that in the independent testing state. So the customer should evaluate and test devices mounted in the customer's products or equipments.

Linde Semiconductor reserves the right to improve the designs, functions and reliability of this product and modify any and all information described in this document without notice customer, apart from that when an notice agreement is signed between customer and Linde Semiconductor.

The information given in this document shall in no event be regarded as a guarantee of conditions or characteristics. With respect to any examples or hints given herein, any typical values stated herein and/or any information regarding the application of the device, Linde Semiconductor hereby disclaims any and all warranties and liabilities of any kind, including without limitation, warranties of non-infringement of intellectual property rights of any third party.